



STUDENT STEEL BRIDGE COMPETITION

2015 RULES



Organizing sponsors of the Student Steel Bridge Competition are

- American Institute of Steel Construction (AISC)
- American Society of Civil Engineers (ASCE)

Co-sponsors are

- American Galvanizers Association (AGA)
- American Iron and Steel Institute (AISI)
- Bentley Systems, Inc.
- Canadian Institute of Steel Construction (CISC)
- DS SolidWorks Corp.
- James F. Lincoln Arc Welding Foundation
- National Steel Bridge Alliance (NSBA)
- Nucor Corporation

This document, which is available at <http://www.aisc.org/nssbc>, describes the Student Steel Bridge Competition and states the 2015 rules for both conference and national levels. **Clarifications, which include any revisions to the rules, are published at that web site and do not appear in this document although they are formal addenda to the rules.** The web site includes other information and the form for requesting clarifications. Information at this web site takes priority over any other source except as noted herein.

TABLE OF CONTENTS

	<u>page</u>
1. Mission and Summary	2
2. Introduction	3
3. Problem Statement	4
4. Eligibility	5
5. Safety	7
6. Scoring	7
7. Schedule of Competition	11
8. Material and Component Specifications	12
9. Structural Specifications	14
10. Construction Regulations	17
11. Load Test Instructions	22
12. Equipment Provided by Host	28
13. Interpretation of Rules	29
14. Judging	29
15. Appeals	30
16. Index of Definitions	32
APPENDIX	
Site and Bridge Diagram	33
Loading Diagrams	34

WELCOME

ASCE and AISC support and encourage the equitable opportunity for participation in the Student Steel Bridge Competition by all interested and eligible individuals without regard to race, ethnicity, religion, age, gender, sexual orientation, nationality, or physical challenges. Bridge teams should be inclusive, open, and fair to all interested and eligible participants.

Section 1

MISSION AND SUMMARY

Civil Engineering students are challenged to an intercollegiate competition that supplements their education with a comprehensive, student-driven project experience from conception and design through fabrication, erection, and testing, culminating in a steel structure that meets client specifications and optimizes performance and economy. The Student Steel Bridge Competition increases awareness of real-world engineering issues such as spatial constraints, material properties, strength, serviceability, fabrication and erection processes, safety, aesthetics, project management, and cost. Success in competition requires application of engineering principles and theory, and effective teamwork. Future engineers are stimulated to innovate, practice professionalism, and use structural steel efficiently.

Students design and erect a steel bridge by themselves but may consult with faculty and other advisors. Students gain maximum benefit if they fabricate the entire bridge themselves. However, because appropriate shop facilities and supervision are not available at all universities, students may use the services of a commercial fabricator if they develop the work orders and shop drawings, and observe the operations. Students are encouraged to maximize their involvement in fabrication.

Safety is paramount. AISC and ASCE request that competitors, advisers, hosts, and judges take all necessary precautions to prevent injury to competitors, judges, host personnel, and spectators. Risky procedures are prohibited. Load testing is stopped if sway or deflection exceeds specified limits, or if collapse is imminent. Bridges that cannot be constructed and loaded safely are withdrawn from competition. In addition, the rules identify and penalize construction errors that represent accidents in full-scale construction.

The Student Steel Bridge Competition provides design and management experience, opportunity to learn fabrication processes, and the excitement of networking with and competing against teams from other colleges and universities.

Section 2

INTRODUCTION

The rules simulate a request for proposal that requires a scaled model to demonstrate the efficacy of competing designs. Section 3, “Problem Statement,” relates the rules to realistic challenges encountered in bridge design and construction.

Sections titled “Material and Component Specifications,” “Structural Specifications,” and “Construction Regulations” set standards for strength, durability, constructability, usability, functionality, and safety that reflect the volumes of requirements that govern the design and construction of full-scale bridges. Criteria for excellence in the award categories of stiffness, lightness, construction speed, display, efficiency, and economy are listed in “Scoring.” Competition judges and the Rules Committee take the role of the owner and have authority to accept and reject entries.

The rules accommodate a variety of designs and encourage innovation. Designers must consider the comparative advantages of various alternatives. For example, a through bridge may be stiffer than a deck bridge but slower to construct. Successful teams compare alternatives prior to fabrication using value analysis based on scoring criteria. The rules are changed every year to renew the challenge and ensure that competitors design and build new bridges.

The rules are intended to be prescriptive but may require some interpretation. The procedure for requesting clarification of the rules is described in section 13, “Interpretation of Rules.”

Competitors, judges, and host personnel are encouraged to read this rules document thoroughly from beginning to end and then review the Competition Guide at <http://www.nssbc.info>. That site also is the source of the official scoring spreadsheet which generates forms for recording data. Judges should be familiar with those forms prior to the competition.

Members of the Student Steel Bridge Rules Committee are

- Michael F. Engestrom, Technical Marketing Director, Nucor-Yamato Steel
- Nancy Gavlin, S.E., P.E., Director of Education, AISC
- Jennifer Greer-Steele, Committee on Student Members Corresponding Member, ASCE
- Frank J. Hatfield, P.E., Professor Emeritus, Michigan State University
- Lawrence F. Kruth, P.E., Vice President, Douglas Steel Fabricating Corporation
- John M. Parucki, Structural Steel Consultant
- Leslie Payne, Director, Student and Younger Member Programs, ASCE
- Craig E. Quadrato, P.E., Director, Civil Engineering Design Group, United States Military Academy
- Don Sepulveda, P.E., Executive Officer, Regional Rail, Los Angeles County Metropolitan Transportation Authority

Section 3

PROBLEM STATEMENT

When asked what would most effectively relieve poverty, the President of Kupicra requested a bridge over the Nogo River which bisects his tropical country, inhibiting commerce between farming villages and H'sogo, the capital city.

Transportation and scheduling will be challenges! The proposed site is accessible only by trails which are impassable during the rainy season. Materials must be transported in loads small enough for ox carts. Accelerated Bridge Construction (ABC) is essential to completing the project during a single dry season.

Consultants to the Sonarpin Foundation, which will fund the project, recommend a steel bridge to minimize the weight of material to be transported and erected, and to facilitate prefabrication, which reduces the duration of on-site construction. Durability and ease of maintenance also favor steel.

Piers in the river and surrounding floodplain would be uneconomic due to a deep layer of organic soil. The Nogo is navigable for a few weeks after the rainy season, so the bridge must provide clearance over the river. Low water levels during the dry season preclude the use of barges but allow construction of a temporary causeway crossing from bank to bank.

The scope of the bridge contract does not include footings, deck panels, or causeway, which will be constructed by local crews.

Your company's proposal is among those that the Sonarpin Foundation deems responsive, and winning the contract would establish your team as a leader in implementing Accelerated Bridge Construction technologies in a challenging environment. Each competing firm is requested to submit a 1:10 scale model to demonstrate its concept. Models will be erected under simulated field conditions and will be tested for stability, strength, and serviceability using standardized lateral and vertical loads. Sonarpin consultants and village elders will judge the models by multiple criteria including durability, constructability, usability, stiffness, construction speed, efficiency, economy, and attractiveness. The contract will be awarded to the company whose model satisfies specified requirements and best achieves project objectives.

Any attempt to gain advantage by circumventing the intent of the competition as expressed by the rules, including this problem statement, will be grounds for rejecting the model and terminating the company's eligibility.

Section 4

ELIGIBILITY

4.1 LEVELS OF COMPETITIONS

There are two levels of competition: conference and national. Conference competitions are held in conjunction with ASCE annual student conferences. Outstanding performance in conference competitions qualifies eligible teams for the national competition.

4.2 CONFERENCE COMPETITIONS

4.2.1 Only one bridge per college or university may compete in an ASCE student conference, and a college or university may compete in only one ASCE student conference.

4.2.2 The ASCE student organization that is hosting a conference may invite guest teams, which are teams from colleges or universities that do not have ASCE student organizations, or from official ASCE student organizations that are assigned to different conferences. Conference assignments are listed in the ASCE Official Register at www.asce.org/offreg/.

4.2.3 A team shall consist only of undergraduate and graduate students in good standing with their ASCE student organization during all or part of fall through spring of the current competition academic year. This requirement is waived for guest teams.

4.2.4 The official scoring spreadsheet shall be used, and all teams (including guest teams) shall be listed on that spreadsheet. The official scoring spreadsheet may be downloaded from <http://www.nssbc.info>.

4.2.5 The host student organization shall promptly submit the completed official scoring spreadsheet for a conference competition to ssbc.results@gmail.com. Teams from that conference will not be invited to the National Student Steel Bridge Competition (NSSBC) until the spreadsheet is received and eligibility is confirmed.

4.3. NATIONAL COMPETITION

4.3.1 A team is not eligible to be invited to compete in the NSSBC if it is

- (1) a guest team as defined in sub-section 4.2.2, or
- (2) from an organization that is not in good standing with ASCE, or
- (3) from an organization that has not satisfied ASCE requirements regarding participation in its conference, or
- (4) ruled to be ineligible to complete its conference competition.

ASCE requirements for good standing and for conference participation are listed at www.asce.org/national-eligibility/.

4.3.2 The maximum number of eligible teams from a conference that will be invited to compete in the NSSBC is based on the number of teams at that conference that competed (that is, presented bridges and staged them for timed construction) but not including guest teams as defined in sub-section 4.2.2.

- (1) Only the single best scoring eligible team will be invited from a conference in which two, three, or four non-guest teams competed.
- (2) The two top scoring eligible teams will be invited from a conference in which five to ten non-guest teams competed.
- (3) The three top scoring eligible teams will be invited from a conference in which eleven to nineteen non-guest teams competed.
- (4) The four top scoring eligible teams will be invited from a conference in which twenty or more non-guest teams competed.

4.3.3 Teams are not invited to compete in the NSSBC as guests.

4.3.4 Only one bridge per college or university may be entered in the NSSBC. Bridges may be modified in preparation for NSSBC.

4.3.5 A team shall consist only of ASCE national members of any grade who were students during all or part of the academic year leading up to the NSSBC.

Section 5

SAFETY

Safety has the highest priority – risk of personal injury will not be tolerated. Sub-sections 8.1, 9.2, 9.4, 10.2, 10.3, 11.1, 11.2, 11.5, and 11.6 of these Rules identify hazardous conditions and actions that will result in withdrawing a bridge from competition if not corrected. Judges will document these safety violations by checking appropriate boxes on the data entry forms. Judges also must comply with and enforce the safety regulations for load testing in sub-section 11.2.

Judges are empowered to halt any activity that they deem to be hazardous. If a bridge cannot compete safely, it must be withdrawn from competition. If the problem is not anticipated by the sub-sections listed in the preceding paragraph, the judge should write a brief description of the problem on the data form.

Students are requested to practice safe fabrication procedures and seek appropriate instruction and supervision. The sub-section 8.2 footnote warns of a welding hazard, and precautions listed in sub-section 11.2.3 guide safe load testing prior to competition.

Section 6

SCORING

6.1 RECORDING DATA, ANNOUNCING RESULTS, SUBMITTING SCORES

Scoring data shall be recorded for every team that competes, using judges' scoring forms printed from the official scoring spreadsheet downloaded from <http://www.nssbc.info>. Data from those forms are then entered in the spreadsheet. After all scoring information has been collected for a team, the scoring official reviews data entry with the captain of that team. The captain is given adequate time to verify the data before signing the form. Then a paper or electronic copy of the team's "Computation" worksheet from the scoring spreadsheet is given to the captain, as soon as possible.

The "Rankings" worksheet from the official scoring spreadsheet summarizes the performance of all teams and is distributed at the awards ceremony, electronically or as paper copies.

The completed official scoring spreadsheet for a conference competition shall be submitted to ssbc.results@gmail.com by the host student organization. Conference results are not final until the spreadsheet is submitted. Questions and comments regarding the spreadsheet should be sent to ssbc.results@gmail.com.

Judges' scoring forms shall be retained by the host student organization for two weeks after the competition.

6.2 CATEGORIES OF COMPETITION

Categories of competition are display, construction speed, lightness, stiffness, construction economy, and structural efficiency. In addition, overall performance is rated.

6.2.1 Display

An award is given for Display. The bridge is presented exactly as it will be erected during timed construction. Display is judged by the following criteria

6.2.1.1 Appearance of bridge, including balance, proportion, elegance, and finish. Quality of fabrication, including welding, shall not be considered because some bridges may be fabricated professionally rather than by students.

6.2.1.2 Permanent identification of the bridge consisting of the name of the college or university exactly as shown on the ASCE student web site, www.asce.org/find-a-chapter/. The name shall be formed from steel or applied to steel with paint or decals, and should be easily legible (lettering at least 1" high is recommended). A bridge that lacks appropriate identification will receive a very low display rating.

6.2.1.3 Poster describing design. The poster shall present the following information

- (1) identification of the college or university, using the same name that appears on the bridge,
- (2) brief explanation of why the overall configuration of the bridge was selected,
- (3) scaled, dimensioned side view of the bridge,
- (4) free-body diagram of the bridge for one of the load cases specified in section 7,
- (5) shear and moment diagrams for the bridge considered as a single spanning beam. The diagrams shall correspond to the free-body diagram, and peak magnitudes shall be shown.
- (6) provisions for Accelerated Bridge Construction (ABC), such as design features, construction sequencing, and procedures intended to minimize construction time, and
- (7) acknowledgement of university technicians, faculty, and others who helped fabricate the bridge or provided advice.

The poster shall

- (1) be flat with maximum dimensions of two by three feet,
- (2) present all information on one side,
- (3) not have attached pages that must be lifted or turned, and
- (4) be in English.

Additional information may be included. Names of financial sponsors may be shown on the poster or on an optional second poster that could accommodate their logos. Electronic displays, decorated supports, lights, and sound are not permitted and will result in the worst possible rating for the poster. A very low rating will be imposed if there is no poster or if it is grossly inadequate. The poster is not part of the bridge but must be in place whenever the bridge is on display.

If English is not the dominant language where the competition is conducted, an optional additional poster may be displayed that is a translation into the local language of the required English language design poster.

6.2.1.4 Display is the tie breaker for all categories of competition. Judges shall not declare ties in display.

6.2.2 Construction Speed

The bridge with the lowest total time will win in the construction speed category. Total time is the time required for construction modified by construction penalties prescribed in 9.4, 10.4.2, 10.4.3, and 10.8.1. There is an upper limit on construction time (see 10.8.2).

6.2.3 Lightness

The bridge with the least total weight will win in the lightness category. Total weight is the weight of the bridge (determined by scales provided by the host student organization) plus weight penalties prescribed in 8.2, 9.3, and 9.5. Decking, tools, lateral restraint devices, and posters are not included in total weight.

6.2.4 Stiffness

The bridge with the lowest aggregate deflection will win in the stiffness category. Aggregate deflection is determined from measurements as prescribed in 11.5.

6.2.5 Construction Economy

The bridge with the lowest construction cost (C_c) will win in the construction economy category. Construction cost is computed as

$$C_c = \text{Total time (minutes)} \times \text{number of builders (persons)} \\ \times 50,000 (\$/\text{person-minute}) + \text{load test penalties (\$)}.$$

“Total time” is defined in 6.2.2, “builder” is defined in 10.1.3, and “load test penalties” are prescribed in 11.5. A penalty increment to the number of builders is prescribed in 10.4.1.

6.2.6 Structural Efficiency

The bridge with the lowest structural cost (C_s) will win in the structural efficiency category. Structural cost is computed as

For a bridge that weighs 400 pounds or less,

$$C_s = \text{Total weight (pounds)} \times 20,000 \text{ (\$/pound)} \\ + \text{Aggregate deflection (inches)} \times 1,000,000 \text{ (\$/inch)} \\ + \text{Load test penalties (\$)}$$

For a bridge that weighs more than 400 pounds,

$$C_s = [\text{Total weight (pounds)}]^2 \times 50 \text{ (\$/pound}^2\text{)} \\ + \text{Aggregate deflection (inches)} \times 1,000,000 \text{ (\$/inch)} \\ + \text{Load test penalties (\$)}$$

“Total weight” is defined in 6.2.3, “aggregate deflection” is defined in 11.5, and “load test penalties” are prescribed in 11.5.

6.2.7 Overall Performance

The overall performance rating of a bridge is the sum of construction cost and structural cost, ($C_c + C_s$). The bridge achieving the lowest value of this total wins the overall competition.

6.3 SPREADSHEET FOR SCORING

The spreadsheet for scoring the competition is also useful for comparing alternatives when designing a bridge. Teams are encouraged to download, understand, and verify the spreadsheet before the competition. It is available in the Competition Guide at <http://www.nssbc.info>. Questions and comments regarding the spreadsheet should be sent to ssbc.results@gmail.com.

Section 7

SCHEDULE OF COMPETITION

In the months before the competition, students design their bridges, fabricate members, test load, practice construction, and select the builders for timed construction.

7.1 RECOMMENDED ORDER OF COMPETITION

The following events occur during the competition

- (1) The official scoring spreadsheet is downloaded from <http://www.nssbc.info/>, and judges' scoring forms are generated from that spreadsheet.
- (2) Bridges are erected for public viewing and are judged for display. After the start of display judging, bridges must not be altered, modified, or enhanced in any way except for repairs prescribed by sub-section 9.4.
- (3) Bridges are disassembled.
- (4) In a meeting at which all team captains are present, the head judge clarifies rules and conditions of the competition, and answers questions.
- (5) The head judge selects the locations of vertical deflection targets and magnitudes of loads. See 11.5 and the Loading Diagrams. Selection is done in the presence of the team captains by rolling a die. For each possible result S of the roll, Table 7.1 gives the dimensions T1 and T2 for positioning the deflection targets, and the magnitudes L1 and L2 of loads.

TABLE 7.1 Determination of T1, T2, L1, and L2

S	T1	T2	L1 (lb)	L2 (lb)
1	9'9"	12'3"	1000	1400
2	7'9"	9'9"	1400	1000
3	7'9"	12'3"	1200	1200
4	7'3"	10'9"	1200	1200
5	7'3"	11'9"	1000	1400
6	9'3"	11'9"	1400	1000

The same locations and loads will be used for all bridges in the same conference competition.

- (6) Using a random process, the head judge determines the order in which teams will compete.
- (7) Bridge members, fasteners, and tools are staged for construction and inspected by the judges. See section 8, "Material and Component Specifications," and sub-sections 10.1.7, 10.2.5, 10.2.6, and 10.6 for details.
- (8) Timed construction. See section 10, "Construction Regulations," for details.
- (9) Judges inspect assembled bridges. For details, see section 9, "Structural Specifications."

- (10) Bridges are weighed (if it is impractical to weigh the entire bridge, its parts may be weighed prior to construction). All bridges shall be weighed, including those that are withdrawn from competition.
- (11) Load testing. See section 11, "Load Test Instructions," for details.
- (12) After a team has completed all phases of the competition, data for the team is transcribed from the judges' scoring forms into the official scoring spreadsheet and checked by the captain. After data entry has been completed, a copy of the team's "Computation" worksheet from the scoring spreadsheet is given to the team captain electronically or on paper.
- (13) Scores and rankings are determined using the official scoring spreadsheet.
- (14) Paper or electronic copies of the "Rankings" worksheet of the official scoring spreadsheet are distributed to captains of all teams at the awards ceremony.
- (15) The host ASCE student organization submits the completed official scoring spreadsheet by e-mailing it to the address given on that spreadsheet.
- (16) The host student organization retains judges' scoring forms for two weeks.

7.2 ALTERNATIVES

The order recommended above may be altered. However, it is essential that

- (1) Bridges are not modified after selection of the load location.
- (2) Bridges are not modified between display judging and timed construction.
- (3) No components or tools are added to or removed from the construction site after staging for inspection.
- (4) Modifications between timed construction and load testing are limited to connection repairs described in sub-section 9.4. Between repairs and load testing, force shall not be applied to the bridge except as necessary to move it. For example, leaning or sitting on the bridge is not allowed.

Section 8

MATERIAL AND COMPONENT SPECIFICATIONS

For the purposes of this competition, steel is defined as an iron alloy that is strongly attracted to the magnet provided by the host organization.

8.1 SAFETY

If any member is not steel, incorporates parts that are not steel, or weighs more than fifteen pounds, the bridge will not be approved for construction or load testing, and will not be eligible for awards in any category. See 8.2.2 for definition of "member."

8.2 DURABILITY AND CONSTRUCTABILITY

Violation of the specifications in this sub-section (8.2) will result in penalties being added to the weight of the bridge. The penalty is 25 pounds for every non-compliant loose bolt and loose nut, and 25 pounds for every non-compliant member plus the weight of that member. See 8.2.2, 8.2.3, and 8.2.4 for definitions of “member,” “loose,” “bolt,” and “nut.”

8.2.1 Bridge

A bridge shall be constructed only of members, loose bolts, and loose nuts. Solder, brazing, and adhesives are not permitted. Exceptions: Purely decorative items such as coatings and decals are permitted, and bridge parts may be labeled.

8.2.2 Members

8.2.2.1 A member is a rigid component comprised of parts welded* together. Bolts and nuts that are welded* to members are parts of members and are not considered to be loose. A member shall retain its shape, dimensions, and rigidity during timed construction and load testing. Members with moving and flexible parts are prohibited. Exception: Deformations caused by mechanical strain (e.g., bending, stretching) during construction and load testing are not violations.

8.2.2.2 A member shall not exceed overall dimensions of 3'0" x 6" x 4". That is, it shall fit into a right rectangular prism (i.e., box) of those dimensions.

8.2.3 Loose Bolts

Loose bolts shall not have parts that flex, move, or are not steel. Nominal length shall not exceed 3" measured from the bottom of the head to the end. Loose bolts shall be commercially available and shall not be mechanically altered or modified in any way but may be painted.

8.2.4 Loose and Welded* Nuts

8.2.4.1 Nuts shall be hexagonal in shape and not have parts that flex, move, or are not steel. Nuts shall be commercially available and shall not be mechanically altered or modified in any way but may be painted.

* **Health advisory:** The bright silvery or colored coating on bolts, nuts, threaded rod, and other hardware contains zinc and cadmium. At welding temperature, both elements create hazardous fumes. Inhalation of zinc fumes causes symptoms resembling those of influenza. Cadmium gas can damage lungs and kidneys, and is a potential carcinogen. **Participants are advised to weld only plain (uncoated) hardware.**

8.2.4.2 Nuts shall have internal threads that extend for the full circumference and length. The threads of a nut shall match the bolt or externally threaded member so that installation and removal require relative rotation.

8.2.5 Holes in Members

8.2.5.1 The hole in a member for a loose bolt or externally threaded part of another member shall be completely surrounded by the member and small enough that the nut or bolt head cannot pass through.

8.2.5.2 Holes in members shall not be threaded. Exception: A nut that is welded to a member and conforms to the specifications of sub-section 8.2.4 is not a violation.

Section 9

STRUCTURAL SPECIFICATIONS

9.1 MEASUREMENT

Conformance with the specifications in this section (9) will be checked with the bridge in its as-built condition after termination of timed construction, before the bridge is moved from the construction site or load tested. The bridge shall not be modified or distorted from its as-built condition in order to conform to these specifications except as prescribed by sub-section 9.4. Dimensions will be checked without decking or applied load.

9.2 FUNCTIONALITY AND SAFETY

If any specification in this sub-section (9.2) is violated, the bridge will not be approved for load testing and will not be eligible for awards in any category.

9.2.1 The bridge shall have two decking support surfaces that are continuous over the full length of the bridge so that decking could be placed anywhere along the span. Decking support surfaces are tops of members. See the Elevation and Section on the Site and Bridge Diagram.

9.2.2 The bridge shall provide access for safely placing 3'6" wide decking and load.

9.2.3 The decking shall not be attached or anchored to the bridge. This prohibition includes but is not limited to protrusions, irregularities, and textures of the decking support surfaces that enhance strength or stability of the bridge.

9.2.4 Decking shall not distort the bridge from its as-built condition.

9.2.5 The bridge shall not be anchored or tied to the floor.

9.2.6 Teams shall construct and load the bridge safely using the site, equipment, and floor surfaces provided by the host student organization. **Bridges and participants shall accommodate local conditions.**

9.3 USABILITY

Specifications in this sub-section (9.3) are illustrated by the Site and Bridge Diagram.

A weight penalty will be assessed for each specification in this sub-section (9.3) that is violated, rather than for every violation of that specification. If there are multiple violations of the same specification, the penalty will be based on the largest violation.

The penalty for violation of each of the specifications in this sub-section (9.3) will be an addition to the weight of the bridge determined as follows

- (1) 50 pounds for a dimensional violation of $\frac{1}{2}$ " or less,
- (2) 100 pounds for a violation greater than $\frac{1}{2}$ " but not exceeding 1",
- (3) 200 pounds for a violation greater than 1" but not exceeding 2", and
- (4) if a violation exceeds 2", the bridge will not be approved for load testing and will not be eligible for awards in any category.

9.3.1 The bridge shall not touch the river or the ground outside the footings. The river is 6'6" wide and the footings are 6'0" from the river banks.

9.3.2 The bridge shall not extend more than 5'0" above the ground or river.

9.3.3 The bridge shall not be wider than 5'0" at any location along the span.

9.3.4 The bridge shall provide a straight rectangular vehicle passageway at least 3'7" wide that completely traverses the bridge from end to end. No part of the bridge, including nuts and bolts, shall be within that minimum width unless it is below the level of the decking support surfaces or at least 1'6" above the level of the decking support surfaces.

9.3.5 Vertical clearance shall be provided under the bridge at all points directly over the river. The clearance shall be at least 1'6" high, measured from the surface of the river. No part of the bridge, including nuts and bolts, shall extend below this limit.

9.3.6 Vertical clearance shall be provided under the bridge at all points directly over the ground. The clearance shall be at least 3 $\frac{1}{2}$ " high, measured from the ground. No part of the bridge, including nuts and bolts, shall extend below this limit. Exception: No clearance is required over the footings.

9.3.7 The decking support surfaces shall be no more than 2'7" above the surface of the river or ground at any point.

9.3.8 Parts of the bridge (including nuts, bolts, and parts that bear on the ground) shall not extend beyond the vertical plane defined by the ends of the decking support surfaces at each end of the bridge.

9.3.9 Decking support surfaces at each end of the bridge shall not extend beyond the vertical plane defined by the footing edge farthest from the river.

9.3.10 The outer edges of the two decking support surfaces shall be no less than 2'6" from one another, and the inner edges of the decking support surfaces shall be no more than 3'2" apart. These dimensions are measured perpendicularly to the span of the bridge. Surfaces outside of the 3'7" limit of specification 9.3.4 are not considered to be decking support surfaces.

9.3.11 Decking support surfaces shall be free of separations and abrupt changes in elevation, except that between segments of decking support surfaces that are surfaces of adjacent members there may be a separation not exceeding $\frac{1}{4}$ ".

9.4 CONNECTION SAFETY

Three minutes will be added to construction time for every connection that violates any specification in this sub-section (9.4) even if it can be corrected.

After termination of timed construction and inspection by the judge, the team is required to attempt to correct every connection that violates specification 9.4.1 or 9.4.2, and will be granted the option to correct connections that violate specifications 9.4.3 or 9.4.4. Only tools that were in the staging yard at the start of timed construction shall be used. A team will be allowed five minutes to correct all connections. If any connection still violates specification 9.4.1 or 9.4.2 when that time limit is reached, the bridge will not be approved for load testing and is not eligible for awards in any category.

9.4.1 Every member shall be connected to every other member that it touches so that they cannot be separated without unscrewing and removing a loose nut or loose bolt, or unscrewing one member from the other.

9.4.2 Every nut shall fully engage the threads of the matching bolt or member. That is, the terminal threads of the bolt or member shall extend beyond or be flush with the outer face of the nut.

9.4.3 Every loose nut shall be tightened sufficiently to contact the member it connects.

9.4.4 Every loose bolt shall be tightened sufficiently so that the head of the bolt contacts the member it connects.

9.5 INSPECTABILITY

All nuts, heads of loose bolts, and threaded ends of bolts and members shall be visible in the completed bridge so that compliance with specifications in sub-section 9.4 can be verified. A penalty of 25 pounds will be added to the weight of the bridge for every threaded end, nut, and bolt head that cannot be inspected.

Section 10

CONSTRUCTION REGULATIONS

10.1 DEFINITIONS

10.1.1 “River,” “staging yard,” “footings,” causeway,” and “construction site boundary” are delineated by the Site Plan on the Site and Bridge Diagram.

10.1.2 “Ground” is the floor inside the construction site boundary, excluding the river but including the causeway and footings.

10.1.3 “Builders” are undergraduate or graduate student members of a team who are within the construction site at the start of timed construction. See section 4, “Eligibility.”

10.1.4 The team designates one builder to serve as “captain” for the entire competition. The captain signifies that the builders are ready to start timed construction, declares the finish, and signs scoring forms.

10.1.5 “Personal protective equipment” consists of a hardhat meeting ANSI standard Z89.1 and protective eyewear or safety goggles meeting ANSI standard Z87.1. A competing organization provides its own personal protective equipment.

10.1.6 A “pouch” is an optional article of clothing that is used to carry nuts, bolts, and tools. This definition encompasses tool belts, magnets, and other accessories worn by builders and having the same function.

10.1.7 A “tool” is a device that is used to construct the bridge but is not part of the completed bridge. A competing organization provides its own tools.

10.1.8 The “constructed portion” is comprised of members, loose nuts, and loose bolts, and is created during timed construction. The constructed portion is not required to be contiguous.

10.1.9 “Member,” “loose bolt,” and “loose nut” are defined in sub-section 8.2.

10.2 GENERAL SAFETY CONDITIONS

Timed construction will not commence or will be stopped if any provision of this sub-section (10.2) is violated.

10.2.1 Builders, judges, host personnel, and spectators shall not be exposed to risk of personal injury.

10.2.2 Only builders and judges are permitted within the construction site boundary during timed construction. Team members who are not builders, coaches, faculty, advisers, other associates of the team, and spectators shall remain in designated areas at a distance from the construction site that assures they are not at risk and cannot interfere with the competition.

10.2.3 There shall be no more than six builders.

10.2.4 At all times during timed construction every builder shall wear personal protective equipment in the proper manner.

10.2.5 A tool shall not weigh more than fifteen pounds. Welding machines and tools requiring external power connections, batteries, or other internal energy supplies shall not be used during timed construction.

10.2.6 Containers of lubricant shall not be in the construction site at any time.

10.3 SAFE CONSTRUCTION PRACTICES

If any rule in this sub-section (10.3) is violated during timed construction, the judge will stop the clock and explain the violation. Before the clock is restarted, builders, tools, members, nuts, and bolts will be returned to the positions they occupied before the violation. Then builders will be asked to resume construction using safe procedures. Builders will have the opportunity to construct their bridge safely. However, if they are not able to construct the bridge completely using safe procedures, construction will cease and the bridge will not be approved for load testing and will not be eligible for awards in any category.

10.3.1 Construction of every non-contiguous part of the constructed portion shall commence by placing a member on the ground within a footing. That member becomes the constructed portion. When a member, loose nut, or loose bolt is in contact with the constructed portion it becomes part of the constructed portion.

10.3.2 At no time shall a builder or builders support the entire weight of the constructed portion or of a non-contiguous part of the constructed portion.

10.3.3 Throwing anything is prohibited.

10.3.4 A builder shall not cross from the ground on one side of the river to the ground on the other side except via the causeway.

10.3.5 Outside the staging yard, a builder shall not simultaneously touch (or touch with tools) more than one member that is not part of the constructed portion.

10.3.6 A pouch or other article of clothing shall not be removed from a builder's person or held in a builder's hand(s).

10.3.7 Nuts, bolts, and tools shall not be held in the mouths of builders.

10.3.8 A builder shall not use the bridge, a constructed portion of the bridge, a member, or a tool to support the builder's body weight. However, a builder may be partially supported by the constructed portion if the builder is kneeling on the floor on both knees, kneeling on the floor on one knee with the other foot on the floor, or standing with the heels and toes of one or both feet on the floor.

10.4 ACCIDENTS

In general, the clock is not stopped when there is an "accident," i.e., an infraction of one of the provisions of this sub-section (10.4).

A penalty is assessed for every accident. If an accident is continuous (for example, a builder stands in the river, or a dropped item is not retrieved promptly) it will be counted as multiple occurrences until corrected. Builders involved in accidents may continue to build. Items involved in accidents shall be recovered promptly and may be used.

Construction cannot depend on deliberately committing an accident. Therefore, the clock will be stopped if any work is accomplished by committing an accident. Before timed construction is resumed, builders, tools, members, nuts, and bolts will be returned to the positions they occupied before the accident.

10.4.1 A builder or builder's clothing touches the river or the floor outside the construction site boundary. For each occurrence, the number of builders is increased by one when the spreadsheet computes construction cost, C_c (the number of builders actually constructing the bridge does not change). Exception: There is no penalty for stepping out of bounds or entering the river to retrieve an object that has been dropped, such as a member, tool, nut, bolt, or personal protective equipment.

10.4.2 A member, constructed portion, tool, loose nut, loose bolt, or personal protective equipment touches the river, the ground outside the staging yard, or the floor outside the construction site. Penalty is 1/4 minute (15 seconds) for every item during every occurrence. Exception: A constructed portion may touch the ground within a footing without penalty.

10.4.3 Outside the staging yard, a member that is not part of the constructed portion touches another member that is not part of the constructed portion. Penalty is 1/4 minute (15 seconds) for every occurrence.

10.5 CONSTRUCTION SITE

See the Site Plan on the Site and Bridge Diagram for layout of the construction site. The host student organization lays out the site before the competition. The construction site shall be laid out so that tape that designates lines is wet or out of bounds. That is, the edges of tapes, not the centerlines, designate the lines shown on the Site Plan.

10.6 START

10.6.1 Before construction begins, only the following are in the staging yard: all builders, members, loose nuts, loose bolts, and tools. Every member, loose nut, loose bolt, and tool must be in contact with the ground and must fit entirely within assigned area of the staging yard as designated on the Site Plan on the Site and Bridge Diagram. Builders are wearing personal protective equipment as well as optional clothing such as pouches. Builders start without tools, nuts, and bolts, which may be passed from one builder to another after timed construction begins.

10.6.2 Judges inspect members, loose nuts, loose bolts, and tools as they are placed in the staging yard. Tools that do not conform to regulation 10.2.5 shall be removed from the staging yard and shall not be used. After inspection and throughout timed construction, additional members, tools, nuts, bolts, or other items shall not be brought into the construction site nor shall anything be removed. Additional builders shall not enter the construction site after the beginning of timed construction.

10.6.3 Timing and construction begin when the captain signifies that the team is ready and the judge declares the start.

10.7 TIME

10.7.1 Time is kept from start to finish of construction. The clock will be stopped under the following conditions

- (1) if a builder or judge sees a condition that could cause injury, or
- (2) when a safety regulation has been violated (see 10.2 and 10.3), or
- (3) when work has been accomplished by committing an "accident." The clock is not stopped if the "accident" does not contribute to the construction process (see 10.4), or
- (4) if a builder or judge is injured.

10.7.2 Construction ceases while the clock is stopped. After the situation has been corrected, builders, tools, and bridge components are returned to the positions they occupied before the interruption, and the clock is restarted.

10.8 TIME LIMIT

10.8.1 If construction time not including penalties exceeds thirty minutes, the scoring spreadsheet will count construction time as 180 minutes. “Accidents” (10.4) that occur after thirty minutes will not be penalized but safety rules (10.2 and 10.3) will still be enforced. Judges may inform the team when this time limit is approaching and shall inform them when it is reached.

10.8.2 If construction time not including penalties exceeds 45 minutes, judges will halt construction. If local conditions allow and the head judge approves, the team may move its bridge off site for continued, untimed construction if it can be done safely. The bridge will not be eligible for awards in any category but, at the discretion of the head judge, it may be load tested after all eligible bridges.

10.9 FINISH

10.9.1 Construction ends and the clock is stopped when

- (1) the bridge has been completed by connecting all the members that were in the staging yard at the start of timed construction,
- (2) all builders are in the staging yard,
- (3) all tools and extra nuts and bolts are held in the hands of builders, or are in clothing worn by builders, or are on the ground in the staging yard, and
- (4) the captain informs the judge that construction is complete.

10.9.2 Installation of decking is not included in timed construction.

10.9.3 After construction is finished the bridge shall not be modified except for repair of connections as prescribed in sub-section 9.4.

Section 11

LOAD TEST INSTRUCTIONS

11.1 DAMAGE

A bridge with damage that would reduce its strength or stability (such as a fractured weld, missing or broken member, broken bolt, or missing nut) will not be approved for load testing and is not eligible for awards in any category. Repair and modifications are not permitted after timed construction except as prescribed by sub-section 9.4.

11.2 SAFETY PRECAUTIONS

It is the responsibility of judges, host personnel, and competitors to employ effectively all precautions, which are summarized in this sub-section (11.2). Competitors should follow the same precautions when proof testing bridges in preparation for competition.

11.2.1 General Precautions

11.2.1.1 An activity shall be halted if the judge considers it to be hazardous. If competitors cannot load their bridge safely, loading will cease and the bridge will not be eligible for awards in any category.

11.2.1.2 Competitors who are not participating in loading, faculty, advisers, and other spectators shall observe from a safe area designated by the judges and host student organization.

11.2.1.3 While participating in load testing, competitors shall wear hardhats meeting ANSI standard Z89.1, protective eyewear or safety goggles meeting ANSI standard Z87.1, work gloves, and leather construction boots. This safety equipment is provided by the competitors. Judges will not permit load testing by competitors who are not wearing the specified safety equipment or are wearing it improperly.

11.2.1.4 Damaged bridges (e.g., broken weld, missing nut, broken bolt, missing or broken member) shall not be tested.

11.2.2 Lateral Load Test Precautions

11.2.2.1 No more than three competitors shall be in the testing area during lateral load tests.

11.2.2.2 Bridges that sway in excess of 1" during lateral load testing shall not be loaded vertically.

11.2.3 Vertical Load Test Precautions

Bridges may collapse suddenly without warning, and a failure may involve only one side so that the load tips sideways. The intent of the provisions of this sub-section (11.2.3) is to prevent personal injury if a bridge collapses.

11.2.3.1 The number of people near the bridge shall be minimized during vertical load tests. No more than three competitors shall be in the testing area during a vertical load test.

11.2.3.2 Safety supports shall be provided by the host organization, and shall be of adequate strength, height, and number to arrest falling load if a bridge collapses.

11.2.3.3 Safety supports shall be in place under the decking units before load is placed on the bridge.

11.2.3.4 The number and location of safety supports under a decking unit shall be sufficient to arrest the load even if only one side or one end of the bridge collapses. Therefore, safety supports are needed under the sides and ends of the decking units, not just in the middle. Safety supports should be directly under decking units rather than under bridge trusses or cross braces, if possible.

11.2.3.5 Safety supports shall be adjusted individually for each bridge so that load cannot drop more than 5". If the height of the safety supports is not adjustable in appropriate increments, they shall be augmented with pieces of wood or other suitable material provided by the host student organization.

11.2.3.6 No one shall reach, crawl, or step under a bridge while any portion of vertical load is in place. If safety supports must be adjusted during loading, the load shall first be removed without disturbing the bridge, adjustments made, and the load replaced as it was before being removed.

11.2.3.7 Bridges that inhibit safely placing vertical load shall not be tested.

11.2.3.8 Load on the decking shall not exceed 400 psf or 500 pounds concentrated.

11.2.3.9 Judges shall observe sway carefully during vertical load testing. If sway exceeds 1", loading shall cease and load shall be removed carefully.

11.2.3.10 Judges shall observe vertical deflections carefully. If deflection at any target exceeds 3", loading shall cease and load shall be removed carefully.

11.2.3.11 Judges shall observe the behavior of the bridge. Loading shall cease and the load shall be removed carefully if, in the opinion of a judge, collapse is imminent.

11.3 PREPARATION

The captain shall observe the load tests.

The judge designates the “A” side of the bridge by a random process. The “B” side is opposite the “A” side. “Left” and “right” ends are determined by facing the “A” side from the outside of the bridge.

Teams shall accept imperfect field conditions such as bent decking, sloping floors, and unfavorable floor surfaces.

At their discretion, judges may impose a penalty for a bridge that incorporates parts having the primary function of interfering with placement of targets, decking, load, or measuring devices. If the bridge cannot be loaded safely, or sway or deflection cannot be measured in accordance with the provisions of this section (11), the bridge shall not be load tested and is not eligible for awards in any category.

“Sway” is translation in any horizontal direction. Typically, sway is determined by using a plumb bob attached to the bridge at a specified target. A sway requirement is failed if any part of the bridge causes the displacement of the plumb bob at floor level to exceed the specified limit, even if the plumb bob is not attached to that part.

11.4 LATERAL LOAD TEST

The provisions of this sub-section (11.4) are illustrated by the Lateral Load Test detail on the Loading Diagrams drawing.

The lateral load test is conducted with one decking unit placed at the center of the bridge and approximately 75 pounds of weight on the decking near the “B” side of the bridge. This load is intended to restrain the bearing surfaces of the bridge from lifting off the floor when lateral load is applied. No additional uplift restraint will be used, even if bearing surfaces lift.

Bearing surfaces are prevented from sliding by lateral restraint applied by competitors. This lateral restraint does not restrain rotation or uplift. The restraint is applied as close to the floor as possible, at the locations shown on the Lateral Load Test detail. Competitors may provide and use optional devices to prevent sliding. The lateral load test is failed if the bridge is restrained in other than the lateral direction, or if the restraint is not applied close to the ground, or if the restraint is not effective.

A sway target is established for measurement on the “A” side of the bridge, 9'9” from the right end of the decking support surface. The sway target is located at the level of the decking or at the top of the decking support surface, which is the bottom of the decking.

Apply a fifty-pound lateral pull and measure the sway. The pulling force is located as close as possible to the decking support surface and not more than 4” from the sway target. To pass the lateral load test, the sway must not exceed 1”.

If the bridge does not pass the lateral load test it is not approved for further testing and is not eligible for awards in any category. Do not conduct any other load test. Check the appropriate box on the judges’ scoring form.

If the bridge passes the lateral load test, proceed with the vertical load test.

11.5 VERTICAL LOAD TEST

The provisions of this section are illustrated by the Vertical Load Test details on the Loading Diagrams drawing. “Deflection” is translation in a vertical direction.

Safety supports are placed under the decking so that no portion of the load will drop more than approximately 5” if the bridge collapses.

Decking units are 3’0” long in the longitudinal (span) direction of the bridge. Two decking units are used for the vertical load test. Place the decking units so that they abut one another with the abutting edges 9’9” from the right end of the decking support surfaces.

Decking units are placed square with the bridge and centered on the decking support surfaces. If grating is used for decking, it is placed with the main bars spanning laterally. Decking units shall not be attached to the bridge and shall not distort it (see 9.2.4).

Three vertical deflection targets are located as close as possible to the decking support surface, which is at the same level as the bottom of the decking. The targets are at the following locations

- A side at a distance T1 from the right end of the decking support surface.
- A side at a distance T2 from the right end of the decking support surface.
- B side 9’9” from the right end of the decking support surface.

T1 and T2 are determined at the beginning of the competition as described by Table 7.1 in section 7, “Schedule of Competition.”

Position measuring devices on the three vertical deflection targets.

Uniformly distribute fifty pounds of preload on each of the two decking units. The preloads are laterally centered on the decking unit. The preloads are located and aligned identically for every bridge.

A decking unit that does not contact the decking support surface at a vertical deflection target will be clamped to the decking support surface at or near that location until the preload has been placed and the vertical deflection measuring devices have been initialized. The clamp will be removed before additional load is placed.

If deflection data is lost (for example, by malfunction or displacement of a measuring device), the judge will require the team to disassemble the bridge and repeat timed construction beginning with the initial conditions prescribed in 10.6. Scoring will be based on the run that results in the larger construction cost, C_c (not including load test penalties), but will not exceed 125% of C_c (not including load test penalties) for the initial run.

Vertical loading produces three measurements

- (1) D1A = absolute value of vertical deflection at the target on the “A” side at T1.
- (2) D2A = absolute value of vertical deflection at the target on the “A” side at T2.
- (3) DB = absolute value of vertical deflection at the target on the “B” side.

The scoring spreadsheet computes aggregate deflection as the sum of those three measurements, rounded to the nearest 0.01”.

Load the bridge and measure the deflections, using the following procedure

- (1) The preload remains in place.
- (2) Initialize the sway measurement device.
- (3) Initialize the three vertical deflection measuring devices or record the initial readings.
- (4) Competitors place L1 pounds of additional load on the right decking unit, and then place L2 pounds of load on the left decking unit. L1 and L2 are determined at the beginning of the competition as described by Table 7.1 in section 7, “Schedule of Competition.” Load is laterally centered on the decking unit and is distributed over the length of the decking unit as uniformly as possible at all times during loading. Load is distributed and aligned identically for every bridge. Load shall be placed at a steady pace, without hesitation.
- (5) As the load is being placed, observe the deflection and sway targets. Stop loading if
 - (a) sway exceeds 1”, or
 - (b) deflection at any deflection target exceeds 3” downward, or
 - (c) decking or any part of the bridge, other than the intended bearing surfaces, comes to bear on a safety support or the floor, or
 - (d) a decking unit or some of the load falls off the bridge, or
 - (e) the bridge collapses or a dangerous collapse is imminent, in the opinion of the judge.

If loading is stopped for any of the situations a, b, c, d, or e, the bridge is not approved for further load testing and is not eligible for awards in any category. Remove the load and **do not continue load testing**. Check the appropriate box on the judge’s scoring form.

If the bridge passes, record the final readings for D1A, D2A, and DB. If any of those values exceeds 2”, the scoring spreadsheet will add penalties of \$8,000,000 to the Construction Economy score and \$20,000,000 to the Structural Efficiency score.

11.6 Unloading

If the bridge collapses during unloading (situation c, d, or e), it is not eligible for awards in any category.

Section 12

EQUIPMENT PROVIDED BY HOST

12.1 SOURCES OF INFORMATION

Equipment for hosting a competition is listed and described by the Competition Guide at <http://www.nssbc.info>. This site also includes competition procedures and illustrations of bridge details that demonstrate compliance and non-compliance with specifications and regulations. Host personnel, judges, and competitors are encouraged to review the site.

Although the equipment described in this section (12) will be provided by the host organization, competitors should acquire similar equipment for load testing before the competition.

12.2 DECKING

Preferred decking is steel bar grating identified as W-19-4 (1" x $\frac{1}{8}$ "). The dimensions of a unit of grating are approximately 3'6" x 3'0" x 1" and the weight is approximately 50 pounds. However, the host may provide a different type of decking with approximately the same dimensions. Grating has significant bending strength only in the direction of the main bars, which are 3'6" long. The grating will be installed with the main bars perpendicular to the length of the bridge, creating a roadway that is 3'6" wide. Therefore, support for the grating is needed for the edges that are parallel to the length of the bridge but not for the edges that are perpendicular to the length.

12.3 SAFETY SUPPORTS

Safety supports must be used during load tests and are intended to limit the consequences of a bridge collapsing. Safety supports shall be of sufficient height, strength, number, and extent so that none of the load will fall more than approximately 5" if the bridge collapses. Safety supports may be steel, nested stacks of plastic buckets, timbers, sand bags, or masonry units.

12.4 LOAD

A total load of 2500 pounds should be supplied in uniform pieces of size and weight that can be handled safely. When in place, the load should not provide significant stiffness in the longitudinal direction of the bridge. The recommended load consists of 25-pound lengths of 5" x 5" x $\frac{5}{16}$ " steel angle placed perpendicular to the length of the bridge. Sacks of material, containers of liquid, concrete blocks, or jacking systems could be used. Decking is not included as part of the 2500 pound load.

Section 13

INTERPRETATION OF RULES

The web site <http://www.aisc.org/nssbc> lists clarifications of the rules. Competitors, judges, and host personnel may submit questions via a form on that web site but should **first read the previously posted clarifications, reread this rules document carefully in its entirety, and review the Competition Guide at <http://www.nssbc.info>.** Submitters' names and affiliations must accompany clarification requests and will be posted with the questions and answers. Internet deliberation by the SSBC Rules Committee typically requires one to two weeks but possibly longer. Questions must be submitted before 5:00 PM Eastern Daylight Saving Time, May 4, 2015.

Section 14

JUDGING

The host student organization will recruit judges. Judges are empowered to halt any activity that they deem to be hazardous. Judges have full authority over conduct of the competition and interpretation of the rules. Decisions, scoring, and ranking are the sole responsibility of the judges and will be final. The host student organization will assure that the judges are fully informed of the rules and procedures, and fully equipped for their tasks. More information for host organizations and judges is available at <http://www.aisc.org/nssbc> and at <http://www.nssbc.info>, where the official scoring spreadsheet may be downloaded and the Competition Guide reviewed.

Section 15

APPEALS

15.1 CONFERENCE COMPETITIONS

15.1.1 At the beginning of the competition each team will identify its captain. The host organization will identify the conference head judge (CHJ).

15.1.2 A penalty, decision, measurement, score, or condition of competition may be appealed only by the team captain and only to the CHJ. The CHJ will not hear the appeal if he or she is approached by students other than the team captain. The CHJ will refuse to hear protests regarding bridges other than the captain's. The appeal must be made as soon as possible after the situation becomes apparent. The CHJ will hear the appeal as soon as possible and may interrupt the competition. If the captain does not consent to the decision of the CHJ, he or she shall write an explanation on the judge's scoring sheet before signing it. Participants are reminded that civility and ethical behavior are expected during the competition and particularly concerning appeals.

15.1.3 After the conference competition, the team captain has the option to appeal the decision of the CHJ by e-mail to Ms. Maria Mnookin <mnookin@aisc.org> or by letter to Ms. Mnookin (AISC, Suite 700, One E. Wacker Dr., Chicago, IL 60601-2001). The e-mail message or letter shall include

- (1) name of the college or university making the appeal,
- (2) captain's name, e-mail address, postal address, and telephone number,
- (3) faculty adviser's name, e-mail address, postal address, and telephone number,
- (4) brief description of the problem, including citation of pertinent rules,
- (5) action taken at the competition to deal with the problem,
- (6) action that the appealing team feels should have been taken,
- (7) data showing that the team should have qualified for national competition, and
- (8) captain's signature (letter only).

The SSBC Rules Committee may ask the host student organization to provide judges' scoring forms documenting the problem and may confer with the CHJ.

15.1.4 Appeals must be made by e-mail or letter. An appeal will be considered only if the e-mail is received or the letter is postmarked by 5:00 PM Eastern Daylight Saving Time on the Wednesday immediately after the conference competition. Ms. Mnookin will forward the appeal to the SSBC Rules Committee for their evaluation. The Committee will not respond to an appeal until the official scoring spreadsheet for that conference has been submitted by the host organization to ssbc.results@gmail.com.

The only redress that may be made is an invitation to participate in the national competition if the Committee is convinced that the appeal is valid and that the appealing team should have qualified for the national competition. Decisions and rankings made by conference judges will not be overturned.

15.2 NATIONAL COMPETITION

15.2.1 Judges will refuse to hear protests from a team concerning any bridge other than their own.

15.2.2 A penalty, decision, measurement, score, or condition of competition may be appealed only by a team captain and only to the station head judge (SHJ). The SHJ will not hear the appeal if he or she is approached by students other than the team captain. The appeal must be made as soon as possible after the situation becomes apparent and before the conditions at issue are changed (e.g., by further construction, loading, or disassembly of the bridge). The SHJ will hear the appeal as soon as possible and will make a ruling. The conditions at issue will not be changed during deliberation. Participants are reminded that civility and ethical behavior are expected during the competition and particularly concerning appeals.

15.2.3 After hearing the SHJ's ruling, the team captain may request a five-minute recess to discuss the issue with the team. During the recess, the conditions at issue will not be changed. Immediately after that recess, if the team has justification to contest the SHJ's ruling, the captain has the option to appeal that decision to the national head judge (NHJ). The NHJ will hear the appeal as soon as possible and will make a ruling. The NHJ may consult with the SSBC Rules Committee. The conditions at issue will not be changed during deliberation.

15.2.4 If the team has justification to contest the NHJ's ruling, the team captain has the option to appeal that decision directly to the SSBC Rules Committee within fifteen minutes after hearing the NHJ's ruling. The Committee may request information from the NHJ and SHJ but those judges will not vote on the final ruling.

15.2.5 The decision of the SSBC Rules Committee is final; there are no further appeals. However, AISC and ASCE welcome written suggestions for improving future competitions.

Section 16

INDEX OF DEFINITIONS

Accelerated bridge construction 3, 6.2.1.3	Load 11.5, 12.4
Accident 10.4	Loose bolt 8.2.2.1, 8.2.3
Aggregate deflection 11.5	Loose nut 8.2.2.1, 8.2.4
Bolt 8.2.3	T1, T2 7, 11.5
Bridge 8.2.1	Member 8.2.2
Builder 10.1.3	Nut 8.2.4
Captain 10.1.4	Overall performance 6.2.7
Causeway 10.1.1	Personal protective equipment 10.1.5
Constructed portion 10.1.8	Pouch 10.1.6
Construction cost 6.2.5	Preload 11.5
Construction economy 6.2.5	River 10.1.1
Construction site boundary 10.1.1	S 7
Construction speed 6.2.2	Safety 5
D1A, D2A, DB 11.5	Safety supports 11.2.3, 12.3
Decking 11.5, 12.2	Scoring form 6.1
Decking support surface 9.2.1	Scoring spreadsheet 6.1
Deflection 11.5	Staging yard 10.1.1
Display 6.2.1	Steel 8
Footing 10.1.1	Stiffness 6.2.4
Ground 10.1.2	Structural cost 6.2.6
Guest team 4.2.2	Structural efficiency 6.2.6
Judge 14	Sway 11.3
L1, L2 7, 11.5	Target 11.4, 11.5
Lateral restraint device 11.4	Team 4.2.3, 4.3.5
Lightness 6.2.3	Tool 10.1.7

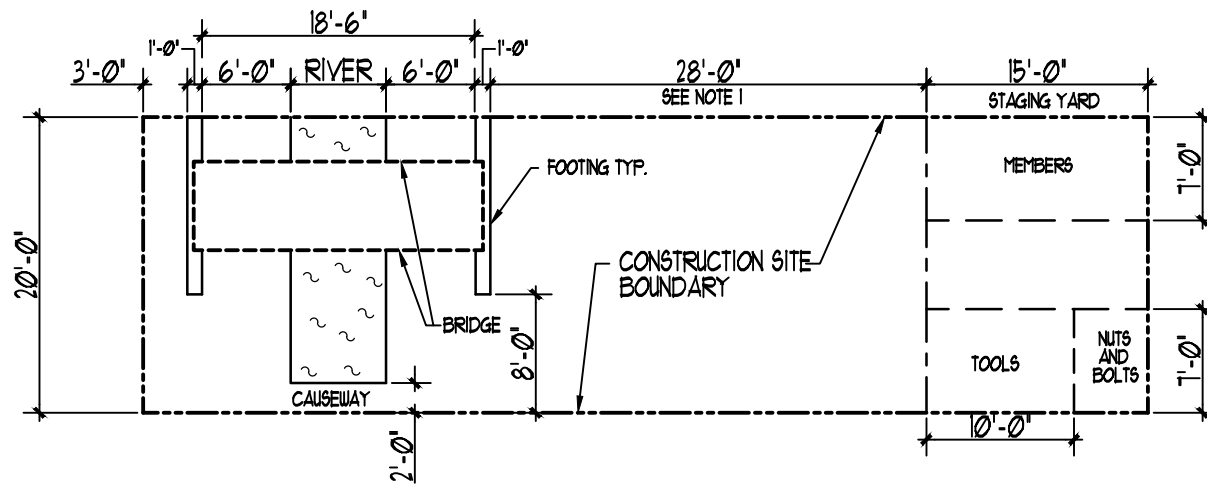

NOTES:

1. LENGTH CAN BE ADJUSTED TO FIT SITE CONDITIONS.
2. BRIDGE SHALL ACCOMODATE DECKING THROUGHOUT OVERALL LENGTH OF THE BRIDGE.
3. NO PART OF THE BRIDGE SHALL EXTEND BEYOND DECKING SUPPORT SURFACES (AT BOTH ENDS).
4. DECKING SUPPORT SURFACES SHALL NOT EXTEND BEYOND THE EDGE OF THE FOOTING (AT BOTH ENDS).
5. 'GROUND' IS THE AREA WITHIN THE CONSTRUCTION SITE BOUNDARY INCLUDING THE FOOTINGS AND CAUSEWAY BUT EXCLUDING THE RIVER.

SITE PLAN - REFER TO CHAPTERS 9 & 10

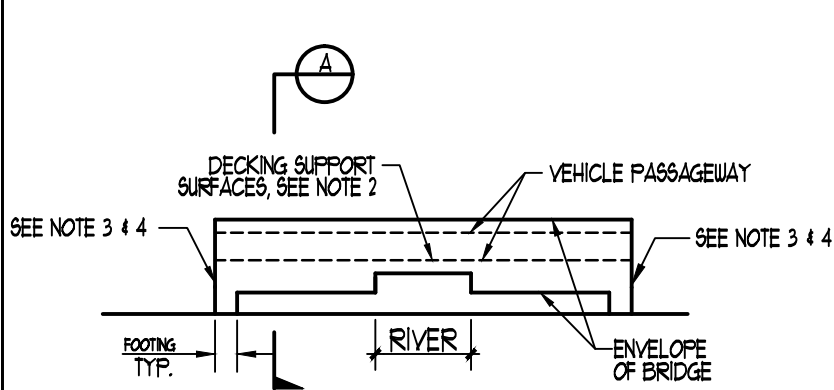

ELEVATION - REFER TO CHAPTER 9

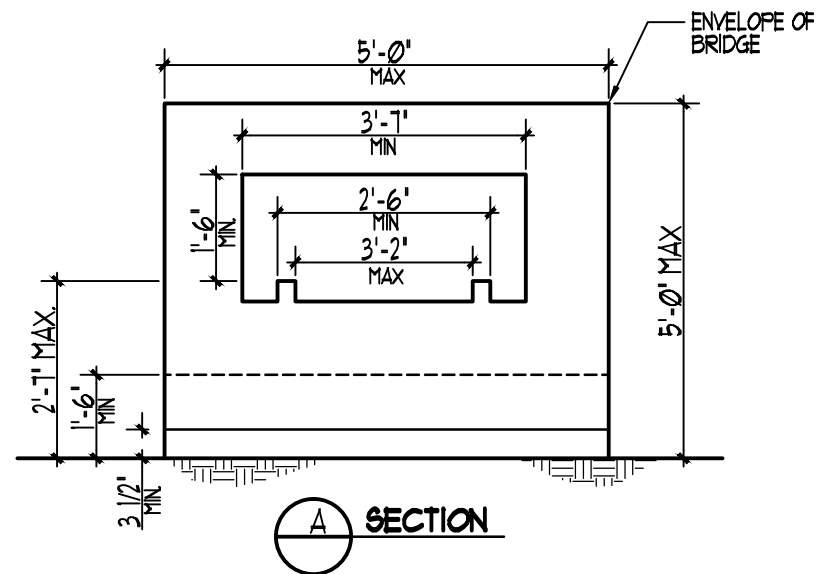

SECTION A

										DESIGNED BY F. HATFIELD		ASCE-AISC STUDENT STEEL BRIDGE CONTEST	SITE AND BRIDGE DIAGRAM	CONTACT NUMBER
										DRAWN BY D. SEFULVEDA				CRAWLING NO. DWG 1
										CHECKED BY RULES COMM.		SUBMITTED: _____ APPROVED: _____	SCALE NTS	
										DATE 08-20-2014			SHEET NO. _____	
REV.	BY	DATE	APP.	REC. NO.	EXPIRES	SEAL HOLDER	DESCRIPTION							

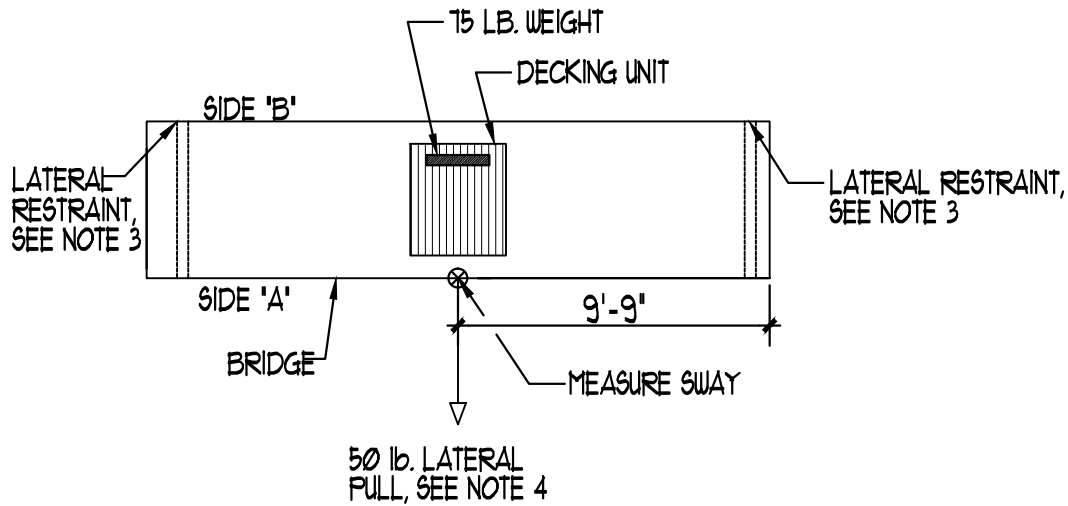

LATERAL LOAD TEST

REFER TO I14

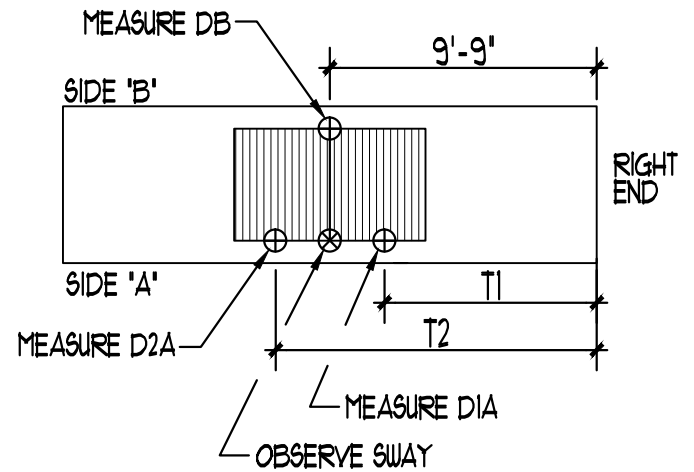

LOCATION OF DECKING AND TARGETS FOR VERTICAL LOAD TEST

REFER TO I15

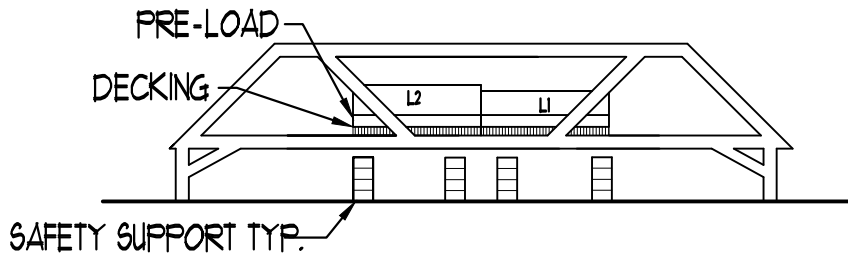

VERTICAL LOAD TEST

REFER TO I15

NOTES:

1. SAFETY SUPPORTS TO BE IN PLACE UNDER THE LOAD AND TO REMAIN AT ALL TIMES DURING LOADING.
2. ALL LOADING SAFETY PROCEDURES TO BE FOLLOWED.
3. LATERAL RESTRAINT MUST BE APPLIED CLOSE TO THE GROUND AND MUST NOT RESTRAIN ROTATION, UPLIFT, OR TRANSLATION IN OTHER THAN THE LATERAL DIRECTION.
4. LOCATION OF 50 lb. PULL SHALL NOT EXCEED 4" FROM SWAY TARGET.
5. SWAY TARGET IS TO REMAIN IN PLACE THROUGHOUT LOADING PROCESS.
6. LOADS ARE CENTERED Laterally AND DISTRIBUTED OVER THE DECKING UNIT AS UNIFORMLY AS POSSIBLE DURING LOADING.
7. OBSERVE SWAY AND TERMINATE LOADING IF SWAY EXCEEDS 1 INCH.

REV.	BY	DATE	APP.	REC. NO.	EXPRES.	SEAL HOLDER	DESCRIPTION

DESIGNED BY F. HATFIELD
 DRAWN BY D. SEPULVEDA
 CHECKED BY RULES COMM.
 IN CHARGE N. GAYLIN
 DATE 08-10-2014



ASCE-AISC
 STUDENT STEEL BRIDGE CONTEST

SUBMITTED _____
 APPROVED _____

LOADING DIAGRAMS

CONTACT NUMBER _____
 DRAWING NO. DWG 2
 SCALE NTS
 SHEET NO. _____